

Small Rasper - Great Opportunities

LARSSON Rasper GL550/300 is specially designed for small capacities.

The rasper is entirely made from stainless steel and fulfills the requirements of easy operation, maintenance and accessibility.

The rotor has the same groove profile for the rasping blades as the larger best-selling GL1000 rasper. The profile makes it possible to place a greater number of rasping blades into the same diameter, compared to a conventional profile.

The rasping blades are clamped between two steel profiles, which allows them to be quickly turned over or replaced. Additionally, the GL550/300 rasper can be supplied with a complete supporting stand that includes frame, trough for slurry and discharge pump.

Laboratory appliance:

- The design facilitates quick product changeover without cross-contamination.
- Frequency conversion, combined with different sizes of screen perforations, enables various grades of product grinding.



LARSSON™ Rasper

GL550/300

Technical Information

Rotor

The rotor is mounted on the shaft using clamp couplings. The shaft and the rotor are fabricated from high quality stainless steel.

The rotor is equipped with 102 rasping blades.

Shaft/bearings

The rotor runs in two standard bearings. Each side of the bearing housing is fitted with a radial seal in combination with replaceable chrome shaft sleeves.

Motor drive

Direct drive to the rotor by means of a tyre coupling.

Motor and rotor are mounted on a common frame made of stainless steel.

LARSSON reserves the right to introduce modifications without notification.

For further technical information, contact LARSSON.

Model	Motor	Weight, kg		Capacity, ton/hour	
		Complete rasper	With supporting stand	Potato	Tapioca
GL550/300	30 kW	1200	1350	5.5	3
	45 kW	1230	1380	8	4.5
	55 kW	1250	1420	10	5.5

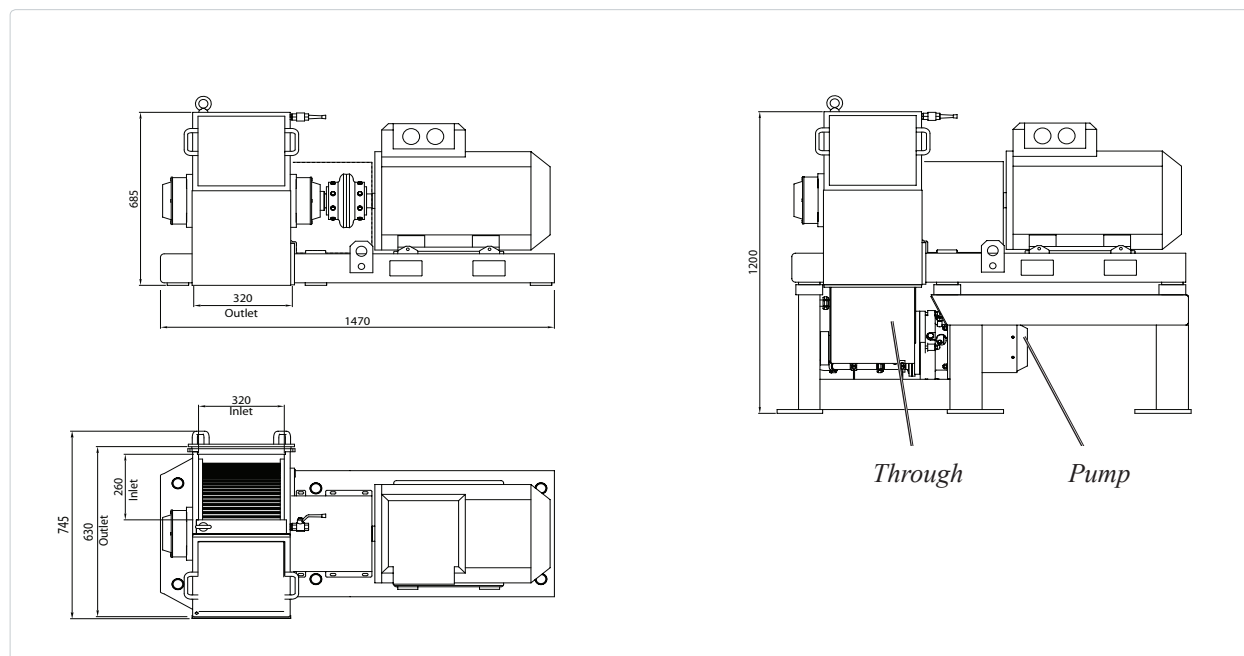

G. Larsson Starch Technology AB, P.O. Box 89, SE-295 21 Bromölla, Sweden.

Visiting and delivery address: Kråkeslättvägen 8, SE 295 39 Bromölla, Sweden.

Phone: +46 456 48660, Telefax +46 456 22690,

E-mail: larsson@larssonsweden.com, Website: www.larssonsweden.com